

FUEL CELLS AS ALTERNATIVE FOR POWER TRANSMISSION OF AUTOMOTIVE VEHICLES

Kazimierz Lejda

*Rzeszow University of Technology
Faculty of Mechanical Engineering and Aeronautics
Av. Powstancow Warszawy 8
35-959 Rzeszow, tel./fax: +48-17 854-31-12
e-mail: klejda@prz.rzeszow.pl*

Abstract

Petroleum as main raw material to production of practical fuels in car engines, is not source of renewable energy. Besides, in result of fuels combustion produced from petroleum (petrol, diesel oil) are emitted pollutants to earth's atmosphere. Therefore in automobile concerns are realized intensive development works, aiming to diminution of fuel consumption and restrict of issue pollutants. Alternative sources of energy to drive cars, which would be able to take place with success of petroleum derivative fuels also are searched. Fuel cells are doubtless of these solutions, which can in nearest future to revolutionize drive systems in car vehicles. In article kinds of fuel cells and their principle of operation has been described. Physical-chemistry parameters of these cells are also compared. In recapitulation prognosis for fuel cells in context development of motorization in the future has been formulated.

1. Preface

In the latter part of 80th years it appeared still, that the future of fuel cells is problematical on account of high prices. Now this situation changes clearly on advantage of galvanic cells, especially thanks to their essential ecological merits. Specialists estimate that replacement of traditional production methods of electric energy from fossil-fuels by fuel cells will reduce emission of carbon dioxide about 40-60% and emission of nitrogen oxides about 50-90%.

The greatest interest of utilization of fuel cells the motor industry shows. This is caused by two reasons:

- by limiting of exhaust pollutions emission in car engines,
- by striving for enlarging of drive efficiency.

The specialists dealing with problems of energy production maintain, that does not exist the second, equally clean technology as fuel cells. Generally one can define the fuel cell as device which transforming chemical energy on electric energy. Speaking otherwise, we supply fuel from one side, and from second side we obtain electric current. All this takes place at high ratio of utilization efficiency of fuel and very low issue of pollutions.

As chemical fuel the most simply would be hydrogen to use. For the motorization purposes considerably more profitably is to use of natural gas, which main component is methane CH_4 (app. 90%). However for the sake of safety the most proper would be methanol CH_3OH .

The fuel cells have several very essential marks, and the most important ones are following:

- lack of moving part,
- possibility of repeated overloads,
- large unit energy (50-800 kJ/kg),
- large unit power (app. 33 W/kg).

Many types of fuel cells exist, which differ from each other in construction, material of electrodes, kind of electrolyte and catalyst. It is difficult to foresee what will be the future devices, because intensive realized works give new solutions now and again. One should expect, that the first models of vehicles with the fuel cells will enter to production about 2008 year, because many technical and technological ideas will demand of finishing up yet.

2. Types and operation of fuel cells

Fuel cell is one from group of galvanic cells, where follows immediate transformation chemical energy in electric energy. Electric energy we receive during proceed in continuous manner chemical reaction of oxygenation of adequate substances delivered to system. Fuel cell is so primary cell, producing electric energy till the time, as long as delivers to its chemical substances. Most often this fuel is hydrogen, however in dependence to uses cell, this can be: carbon, carbon monoxide, alcohol. Most profitable fuel in motorization is e.g. methane or methanol [5,6,8].

Fuel cell consists of anode, cathode and electrolyte. Electrolyte often is in solid form as electrolyte matrix. Fuel flows to anode and oxidant (clean oxygen or as component of air) flows to cathodes. Reacting substances of combustion process not join immediately, instead course of the electrochemistry process causes formation of electric energy. Flow of electrons go on outside cell by electric energy receiver, and close of electric circuit executes by ions flowing in electrolyte between electrodes. Cells unites in batteries to receive greater electric energy. From one cells is obtain on the average voltage in limits 0,6-1,0 [V].

Important in operation of fuel cell is proper kinetics of electrode reaction and occurrences of polarization. Each chemical process can reach only then, when each particles of substrates will have sufficient energy to exceed of activation reaction barrier. The more of particles will reach energy equal activation energy, the greater is speed of reaction. For assurance suitable of reaction kinetics the electrode has to be with good catalytic activity. With the aim diminution of diffusion polarization present electrodes have most often porous structure.

Nowadays exists many kinds of fuel cells, which differs of construction, material of electrodes, kind of catalysts, properties of electrolyte, temperature of exploitation etc. According on replaced differences, fuel cells we can generally divide on [4]:

- low-temperatures,
- high-temperatures.

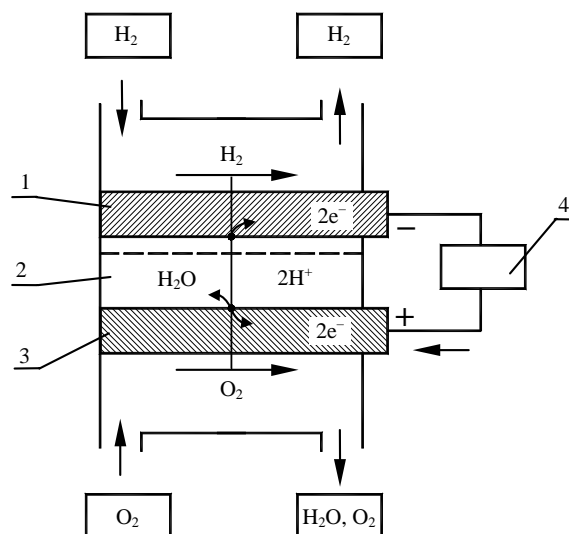

Fig. 1. Schema of low-temperature fuel cell: 1 - anode, 2 - electrolyte, 3 - cathode, 4 - electric energy receiver

From among of low-temperatures fuel cells we differentiate following kinds:

- alkaline fuel cell (containing 30% of potassium hydroxide, exploited to temperature 100°C),
- solid-polymer fuel cell (electrolyte is exchange membrane with sulfone-fluorine-carbon polymer, exploited to temperature 130°C),
- phosphoric acid fuel cell (electrolyte is 100-percentage phosphoric acid, exploited in temperatures 130-220°C).

Processes of electrochemistry oxygenation in low-temperatures fuel cells proceed according to schema represented on Figure 1.

In anode zone proceed following chemical reactions:



In cathode zone course of chemical reactions are following:

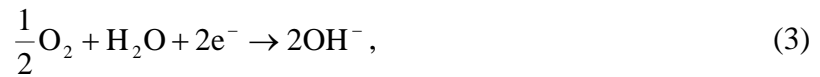

In high-temperatures cells the processes of electrochemistry oxygenation proceed different than in low-temperatures cells [8]. Then mostly it's caused with kind of electrodes material and properties of electrolyte. High-temperatures cells we divide on following kinds:

- molten carbonate fuel cell (electrolyte is mixture $\text{Li}_2\text{CO}_3\text{-K}_2\text{CO}_3$ or $\text{Li}_2\text{CO}_3\text{-Na}_2\text{CO}_3$, anodes are made from the porous nickel, cathodes are made from the porous of nickel oxide, exploited in temperatures 620-650°C),
- solid oxide fuel cell (electrolyte is matrix executed most often from zirconium oxide, plates are covered two-sided of anode and cathode materials, anodes are made on base Ni- ZrO_2 , cathodes are made on base of manganese oxides or cobalt, exploited in temperatures 800-1000°C).

Schema of course of reactions in high-temperatures carbonate fuel cells represents Figure 2.

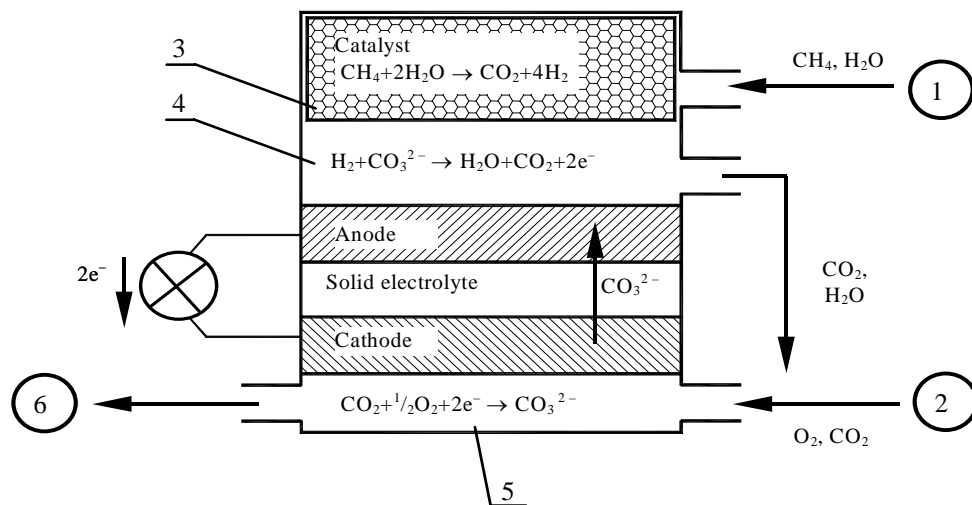
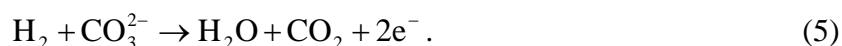

Fig. 2. Schema of electrochemical reactions in high-temperature molten carbonate fuel cell: 1 - natural gas with steam, 2 - air with exhaust gas, 3 - catalytic reforming of methane, 4 - reaction on anode, 5 - reaction on cathode, 6 - exhaust gas on outlet from cathode

The transfer of oxygen in high-temperatures carbonate fuel cells from cathode to anode is realized by carbonate ion CO_3^{2-} . Mixture of potassium and lithium carbonates fuses in temperature 480°C , what assures its excellent electrolytic conductivity in temperature 650°C . Carbon dioxide and oxygen well melt in carbonate electrolyte and create carbonate ion. Produced carbonate ion diffuse by electrolyte to anode and there reacts with hydrogen to carbon dioxide and water. Course of reaction on anode side is following:



On cathode side the chemical reaction runs according to equation:



The shortened characterization of low-temperatures and high-temperatures fuel cells are represented in Table 1.

Table 1. Characterization of fuel cells types

Fuel cell	Temperature of work [$^\circ\text{C}$]	Kind of electrolyte	Fuel	Oxidant	Efficiency [%]
Alkaline	80-90	alkaline solution KOH, NaOH	hydrogen	oxygen	50-65
Solid-polymer	70-90	polymer membrane	hydrogen, methanol	oxygen, air	50-65
Phosphoric acid	160-220	phosphoric acid H_3PO_4	hydrogen, methane	air	35-45
Molten carbonate	650	potassium carbonate K_2CO_3	hydrogen, methane, coal gas	air	45-60
Solid oxide	850-1000	stabilized zirconium and yttrium $\text{ZrO}_2, \text{Y}_2\text{O}_3$	hydrogen, methane, coal gas	air	50-60

3. Application of fuel cells to automotive vehicles

Automobiles industry at present demonstrate large interest with use of fuel cells as sources of drive in cars. Following limits of toxicity forced on producers of car engines cause necessity of research on alternative sources of energy, without making worse of drive efficiency. Fuel cells realize desirable criterions, but barrier stays high cost of these devices. With moment use of them on large scale, what warrants car industry, individual costs of fuel cells can prove economically remunerative.

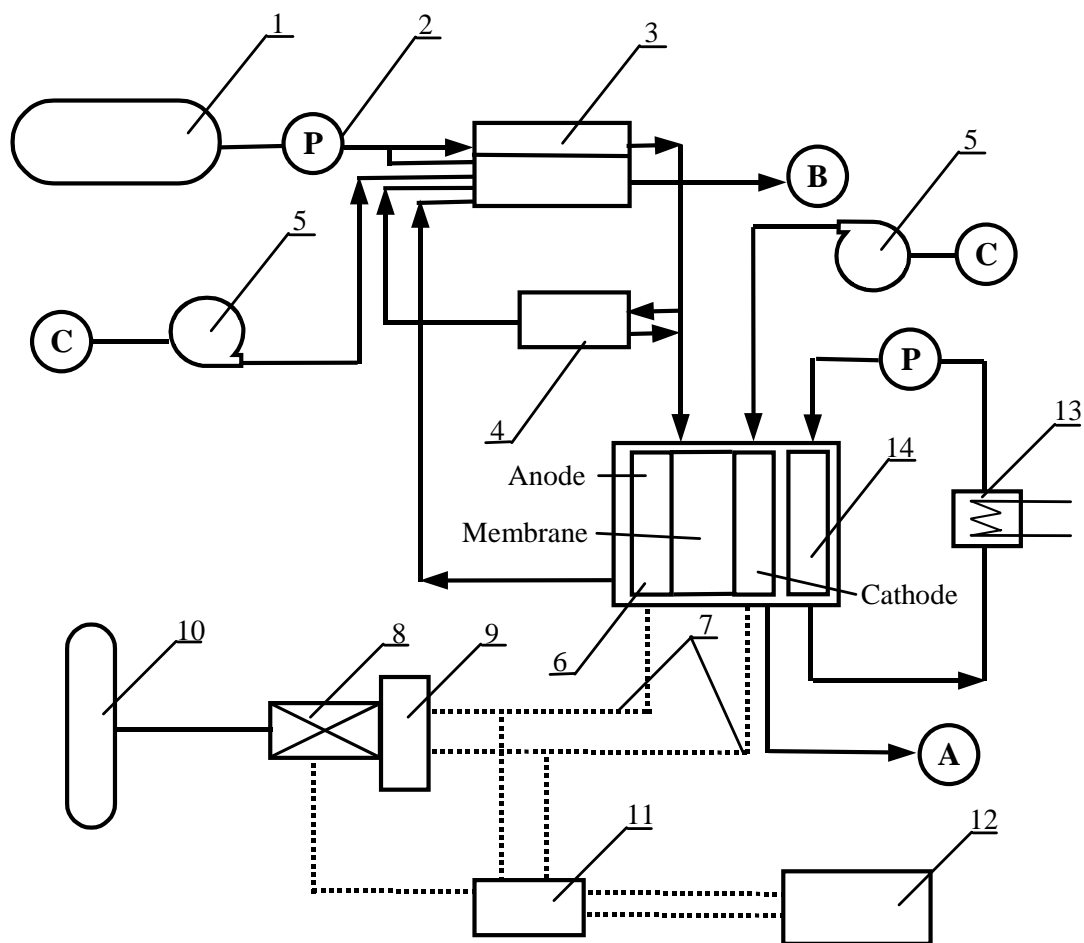
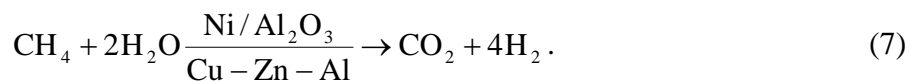

Fig. 3. Fuel cell on the base of methanol installed in car: 1 - methanol / water ratio 4:6, 2 - pump (P), 3 - reforming (chemical change of methanol on hydrogen and carbon dioxide), 4 - equalizing tank of hydrogen, 5 - air blower, 6 - low-temperature fuel cell, 7 - electric wiring, 8 - electric motor, 9 - speed controller, 10 - wheel drive, 11 - controller of charging battery, 12 - battery, 13 - heat exchanger, 14 - cooler, A - gas on cathode, B - gas on anode, C - air

Research prove, that to motorization aims the best fuel in fuel cells would be usage of natural gas, which main component is methane. Profiting from high temperatures in anode chamber can realize two-stage reforming with steam according to reaction:



Suggests also, that from regards of safety to drive of cars proper would be methanol, which in cell is converted to hydrogen. Schema of fuel cells on base of methanol with elimination of piston engine is showed on Figure 3. The reaction in fuel cell with methanol is proceed in temperature 80-90°C and at pressure 3,0 bar. Cell is helped with accumulator battery, consisting from 44 cells NiMH joint in series.

In development of fuel cells to drive of car vehicles appear however essential problems connected from them ageing. Refuses contained in fuel cause gradual clogging some pipe of porous electrodes, what considerably limits flow of hydrogen and oxygen ions. In this way reduces current efficiency of cell. Constructors and engineers aspires to obtainments of sets about vitality near 40.000 hours. This will assure necessity of exchange all power block in vehicle on the average of 5-7 years.

To motorization may be different fuel cells applied. In Table 2 possibility of principal applications of some fuel cells are shown [3].

Table 2. Principal application of some fuel cells

Type	Electrolyte	Operating temp, (°C)	Principal applications
PEMFC	Poly-perfluoro sulfonic acid	25-105	Transport
DMFC	Poly-perfluoro sulfonic acid	70-105	Transport
SOFC	Zirconium & yttrium oxides	750-1000	Transport, power generation
AFC	Potassium hydroxide	50-200	Space, transport
MCFC	Lithium and potassium carbonates	630-700	Power generation
PAFC	Phosphoric acid	180-210	Power generation

Key: SPFC – solid polymer fuel cell; SOFC – solid oxide fuel cell; AFC – alkaline fuel cell; PEMFC – proton exchange membrane; MCFC – molten carbonate fuel cell; DMFC – direct methanol fuel cell; PAFC – phosphoric acid fuel cell

Fuel cells are being developed by specialized companies, like Ballard, which established precompetitive development venture – XCELLSiS and American – Global Alternative Propulsion Center (GAPC), which employs 200 engineers in USA and Germany. Companies: Toyota, Honda, Nissan and Mitsubishi have their own Japan center to develop fuel cells. Ballard develops hydrogen PEMFC. During working on fuel cells, Ballard obtained 400 patents in PEMFC technology. Power density of new Mark 900 FC is as much as 1,35 kW/dm³ (former Mark 700 FC – 1,0 kW/dm³).

Table 3. Overview of fuel cells developed by Daimler Chrysler based on different fuel concepts

Car type	Year	Fuel	Voltage	Power of the system	Power/Mass
NECAR I	1984	Hydrogen	230V	50 kW	21 kg/kW
NECAR II	1986	Hydrogen	280V	50 kW	6 kg/kW
NEBUS	1987	Hydrogen	720 V	250 kW	5,6 kg/kW
NECAR 3	1987	Methanol	300 V	50 kW	15 kg/KW
JEEP COMMANDER STUDY	1988	Gasoline	250 V	50 kW	39 kg/ kW
NECAR 4	1999	Liquid hydrogen	330V	70 kW	5 kg/kW
NECAR 4	2000	Methanol	250 V	75 kW	-

GAPC develops methanol FC for GM and Daimler Chrysler. Presently more than 20 companies develop fuel cells.

As for as auxiliary energy source are concerned, BMW first installed fuel cells in 750i type car to meet the needs of electronic systems. Gasoline SOFC operates at 800°C via

zirconium oxide ceramics. Fuel cells uses $0,7 \text{ dm}^3$ per 100 km (normally SI engine used $1,5 \text{ dm}^3$ gasoline to power electric systems).

The simplest fuel cell is that, which uses hydrogen. Both, the hydrogen gas and atmospheric air can be supplied directly to fuel stack without prior treatment. Such fuel cells are developed by the most of companies. In Table 3 (Scherer and Rödre 2001) overview of fuel cells developed by Daimler Chrysler based on different fuel concepts for example is shown.

Fuel cell vehicle is the only alternative for zero emission vehicle (ZEV) for its forecast development. Development of fuel-cell vehicle (FCV) is out of discussion, but the problem is in the fuel to fuel cells how to store it onboard vehicle. Also very serious problem is to build infrastructure – filling stations. Fuel option for fuel cell is shown in Figure 4.

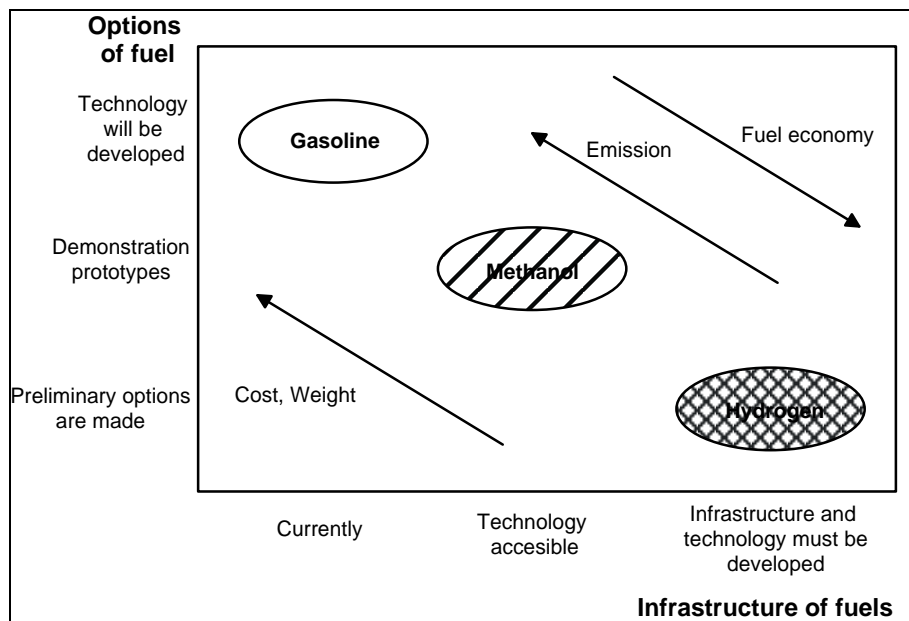

Fig. 4. Fuel option for fuel cells in automotive applications versus infrastructure cost

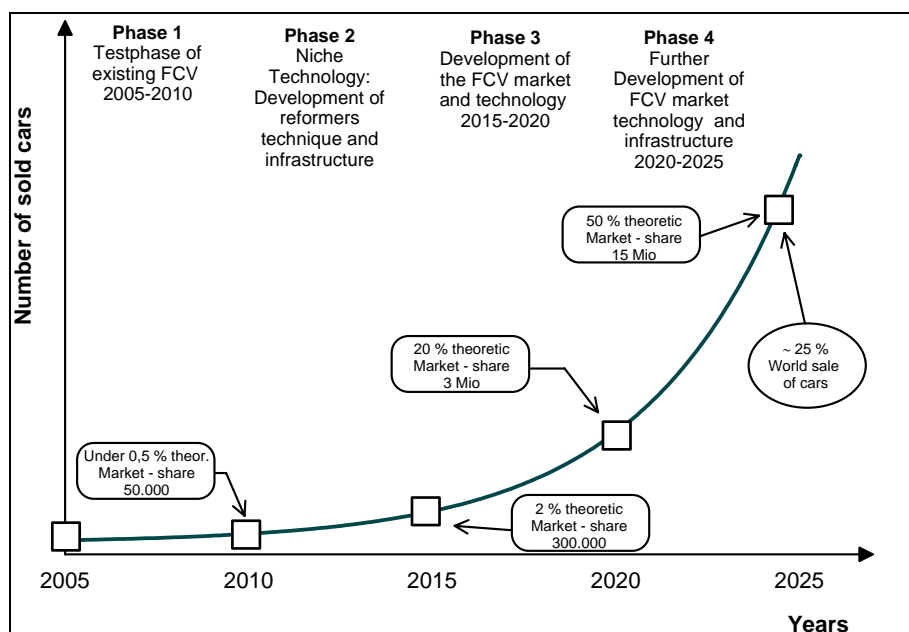

Fig. 5. Foreseeable market scenario of fuel cell cars

First gasoline fuel cells will be introduced to production vehicles, due to its multiplicity in the market. Next will be methanol and then hydrogen, the fuel of future. First FCV will appear in the year 2006. Scenario of market fuel cell cars is shown in Figure 5 [9]. FCV will be introduced to the market step by step.

4. Conclusion

Analysts of motorization technology development foresee, that first models of car vehicles with fuel cells will introduce into production of about year 2008 [1,2]. This is as far as real time -limit, because many of technical and technological problems will still require in detail of finishing up. However, conviction in relation advisability introduction of this drive sources in cars is more and more underlined in group of specialists. Advantages in range of environment protection are irrefutable. This will permit to save petroleum too, which will can use more rationally in other branches of industry (chemistry, pharmaceutical etc). Total efficiency of cars with fuel cells oscillates in limits 30%, while efficiency with internal combustion engines does not exceeds 12-15%.

Summing up we can with all responsibility to confirm, that fuel cells determine important challenge for nowadays used sources of energy. First of all are perceived in them clean ecological energy, not causing degradation of natural environment. This impels doubtless imagination of specialists which interest of energetic problems in global scale. Motorization, which is one from main emitters of pollutants into environment is convicted finally on new sources of energy.

5. References

- [1] Burke M., Electrochemical Capacitors for Electric Vehicles-Technology Update and Implementation Considerations. Proceedings of 12-th International Electric Vehicle Symposium, 1994.
- [2] Cuddy M., Wipke K., Analysis of the Fuel Economy Benefit of Drivetrain Hybridization. SAE, №970289.
- [3] Kowalewicz A., Fuel Cell Power for Future. Journal of KONES'2001, Vol. 8, № 3-4, Warsaw 2001.
- [4] Merkisz J., Ekologiczne problemy silników spalinowych. Tom 1 i 2. Wydawnictwo Politechniki Poznańskiej, Poznań 1999.
- [5] Norbeck J., Heffel J., Durbin T., Tabbara B., Bowden J., Hydrogen Fuel for Surface Transportation. University of California 1995.
- [6] Pandit G., Alternativ Fuels in Future Vehicles. Automotive Engineering, № 1/1996.
- [7] Riley R., Alternative Cars in the 21st Century. Warrendale: Publ. By SAE, ISBN 15096-0001.
- [8] Sarangapani S., Lessner P., Kosek J., Giner J., Methanol Fuel Cell. The Elektrochemical Society Inc.- New York 1998.
- [9] Scherer G., Rödre A., Auswirkung der Brennstoffzellen-Technologie auf die Alternative im Automobilbereich. ATZ, № 4/2001.